

Smart Control Solutions

“Smart Buildings for Smart People. Winona Controls...Doing it Smart”

AMERICAN
AUTO-MATRIX®

1. About

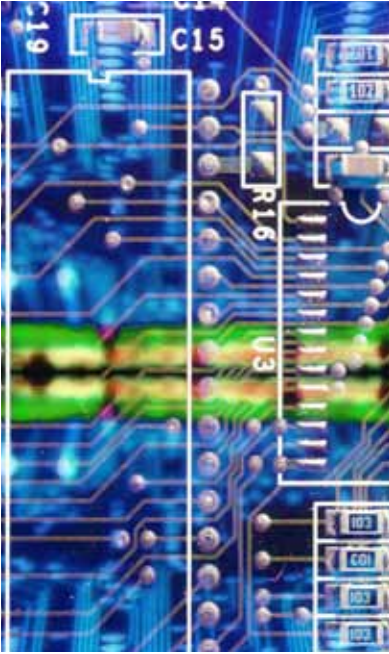

Safety, quality and cost-effective performance are the foundation of Winona Controls. Since 1991 we have provided service for mechanical systems in commercial and industrial facilities. Purchased by Adam Augedahl and Matt Phillip in 2009, Winona Controls has continued its dedication to customers by always providing dependable, fast, productive, quality service.

True Innovation...

True innovation requires flexibility. That is why Winona Controls offers American Auto-Matrix® solutions. They provide flexibility beyond comparison in the building automation industry today. Whether your project requires a single controller with a touchscreen small display, has a significant number of points and requires a web interface solution, or entails an enterprise level of sophistication, we have the right architecture for you.

American Auto-Matrix has been providing “Smart Building Solutions®” for over 30 years with a system architecture that is built upon the notion of open protocols and backwards compatibility. All of their products feature generation-to-generation compatibility, which means each new product is carefully engineered to build on and function smoothly with its predecessors. With facilities worldwide still utilizing controllers installed in the early 80’s until the present, we know it is important for customers to have the support and technology they need to maintain or upgrade their facilities without high costs.

Your Building - The Complete Picture

Using state of the art technology from American Auto Matrix, Winona Controls gives you a complete picture of how your building operates. With a Direct Digital Control System you will be fully aware of system operations. Your building is an investment. Get the maximum efficiency out of it.

Building status information should always be at your fingertips. Let us show you how our extensive experience in the automation industry can help you answer...

- Is my system still operating as it was originally designed?
- Are there newer, more cost effective methods?
- Do I need to consider replacing aged equipment?
- Is my building outgrowing my current system?
- Do I gather an accurate history of operating conditions?
- Do you wish your building would let you know immediately if there is a problem?

Protocols

American Auto-Matrix has always realized the importance of open systems architecture for Building Automation Systems. They pioneered the concept of open protocols for building automation systems in the mid 1980s with their Public Host Protocol™ (PHP) and Public Unitary Protocol™ (PUP) systems. AAM’s philosophy of open communication systems finally became widely accepted and specified in the industry decades later with the emergence of BACnet® and LonMark®. Today American Auto-Matrix manufactures product which adheres to these industry standards and continues to lead the way in the world of open architectures.

Proprietary:

The PUP and PHP protocols have been developed with backwards compatibility in mind and are used with their SOLO and SBC product lines to provide customers with a solution for system architectures that have an expressed need for a closed, proprietary solution.



BACnet®:

By taking advantage of the BACnet® standard in their NB line of controllers, American Auto-Matrix gives its customers the interoperability they desire and the security of knowing that they are not locked to a single vendor. This encompasses all aspects of a facility including card access, fire and life safety, security, lighting, and HVAC.



Through the use of powerful proprietary and open protocols AAM is able to offer flexibility combined with backward compatibility and constant future innovation, meeting every building automation need.

Area Controller: Front End Solutions

What's Your

ASPECT?

With American Auto-Matrix's AspectFT Product Family, you truly get an open, web-enabled HVAC energy control solution that is designed to allow access to your building from a standard web browser. Utilizing open web solutions, your building can be controlled in a manner that promotes energy efficiency through the display of real-time information via RSS feeds, simple

mobile web access, and online scheduling integration through programs such as Google™ Calendar, Outlook® 2007, and Apple's iCal™ (over 45 calendaring programs can be utilized). By using current open technologies available or web-enabled portable device and internet access, users are quickly able to link to their building automation system and schedule changes and view live data

related to everything from energy consumption to alarms and temperature trends. Also, through "out-of-the-box" MySQL read and write functionality, data utilized for energy management applications can be mined easily and readily through the use of this standard data storage protocol. Also, with the flexibility of Java, and the tested Linux platform, users' data and information can be displayed in almost an infinite number of ways. Lastly, you can interface with your building through Twitter, meaning receiving data as well as manipulating data can now be accomplished through a single tweet!



Aspect^{FT} : This is the control engine found on the Matrix responsible for running control sequences and building management routines. It is the Facilitating Technology.



Aspect^{FT} Facility : Designed with the larger project in mind, this version comes on its own server and allows users the ability to communicate with multiple Matrix area controllers.



Aspect^{FT} Enterprise : With integration becoming an important factor in building management, this version allows the installer the ability to choose the hardware utilized for running AspectFT with multiple Matrix area controllers.



Aspect Studio : Through this intuitive block-based programming software, users create logic based programming projects as well as graphical representations to deploy via Ethernet to a Matrix or other hardware device.

Network Controller

What is the Matrix™?

Through intuitive design and technology, the Matrix™ is a family of embedded network controllers, providing many features and functions not found in competitive building controller products. Using Matrix, users can control and manage their building auto-mation system over any network or Internet connection. Included within the AspectFT control engine is an embedded web-server. With this, users can interact with their system using any standard web-browser.

MATRIX

"If your building cannot give information virtually whenever or wherever you need it, *are you really in control?*"

Sustainability

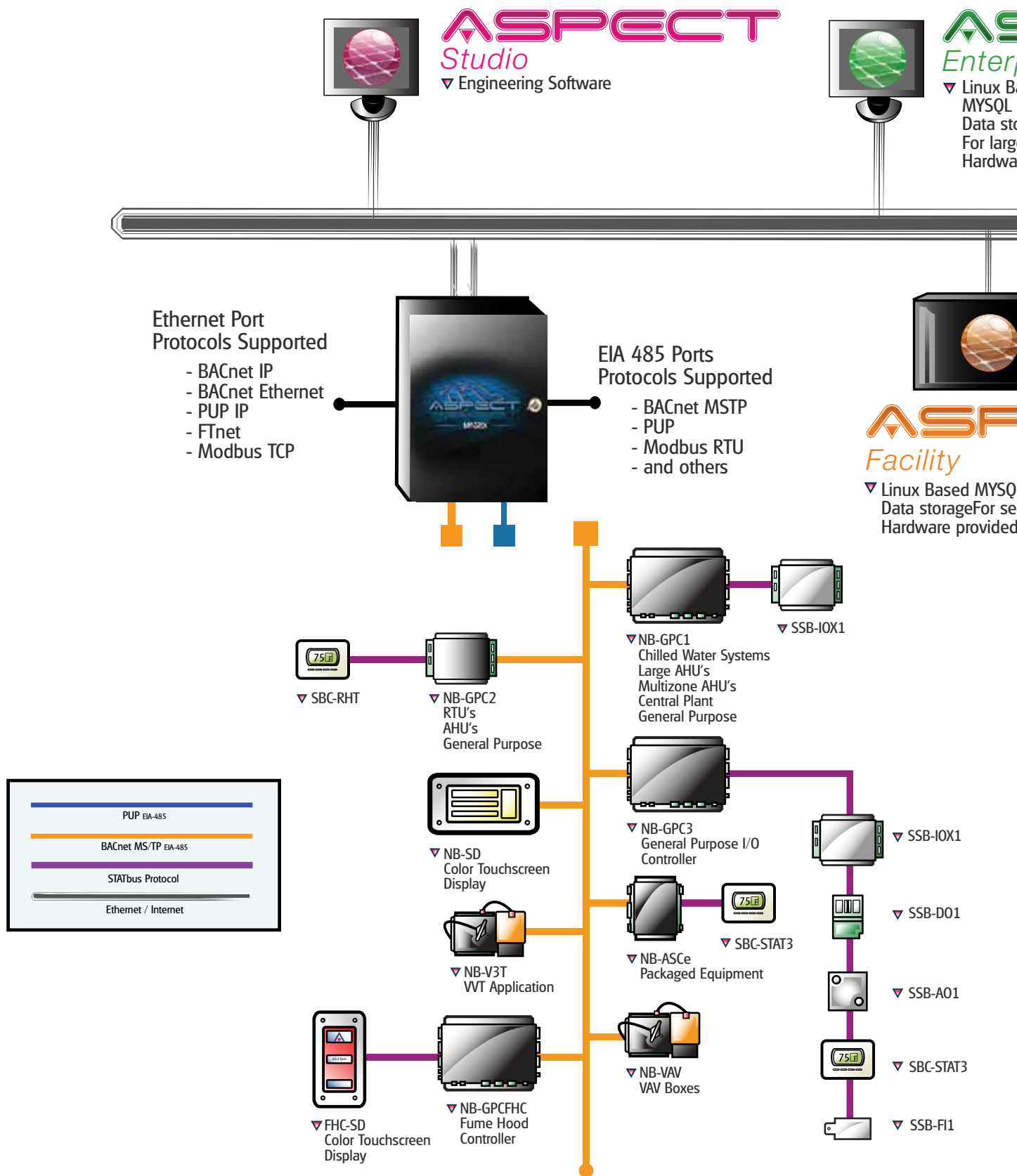

The American Auto-Matrix System Architecture provides the capability to achieve efficient and powerful Building Automation Control. Utilizing the power of AspectFT, our system architecture provides a robust platform for integrating multiple data sources into one unified solution. With the AspectFT control engine, you are not limited to just one solution. As the Facilitating Technology (FT), this software platform is based upon open-standards used within multiple industries. Designed to perform control sequences and building management routines from an array of device platforms, AspectFT can communicate utilizing drivers such as BACnet®, PUP, and Modbus™. Through varying aspects of the software, a solution can be scaled based on size and control they expect.

SPECT FT

based
 Database
 Storage
 server applications
 are qualified by AAM

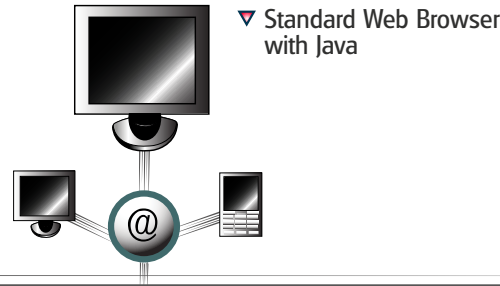

SPECT FT

L Database
 server applications
 by AAM

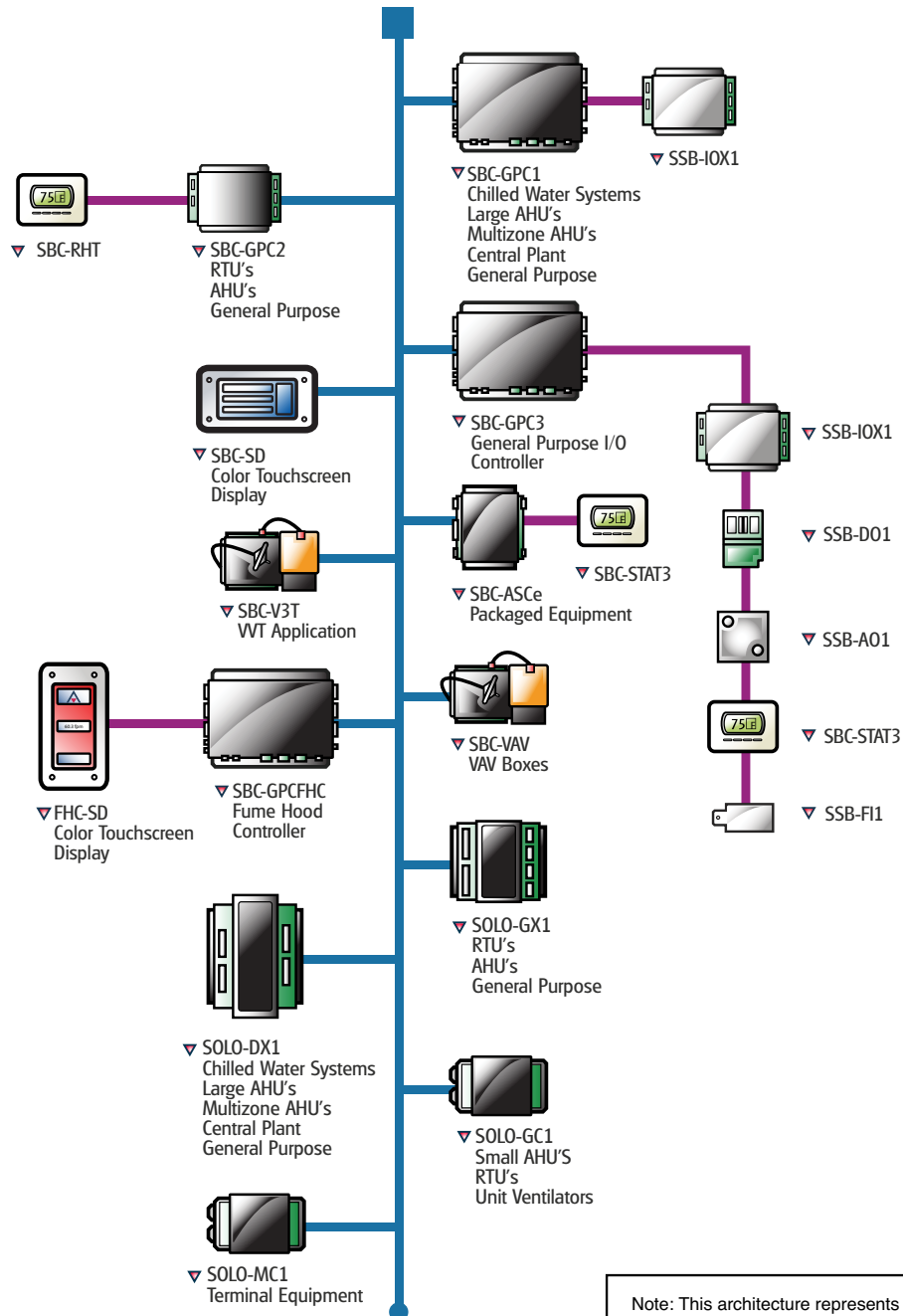

Note: This architecture represents multiple design scenarios, including possible migration and expansion solutions. As with all architectural representations, functionality and performance are dependent upon controller capabilities and application parameters.

5. Controllers

Unitary Controllers

AAM Unitary controllers can operate stand-alone or networked together to form a complete system. From small stand-alone buildings, to multiple building networks, to enterprise wide applications, the AAM system offers the same level of *durability, functionality, and flexibility* wherever they are found. These controllers are available in both PUP and BACnet® protocols.

Use American Auto-Matrix Unitary Controllers when you need:

- smart, stand-alone, application-specific DDC
- unitary control networkable to a higher-level automation system
- reduced installation time and cost
- superior local control performance at lower operating costs
- reliable, high-speed communications over twisted pair wire

The GPC Product Family takes advantage of the STATbus™ technology, a two-wire, polarity insensitive sensor networking protocol that can significantly reduce the installed cost of I/O intensive systems. The STATbus™ technology and the design of the GPC allows for rapid configurations resulting in easier, more efficient engineering, installation, and commissioning.

The ASC(e)/VAV/V3T Product Family is based on a common hardware platform that is dedicated to application specific controllers. The ASC(e) controller is an application selectable controller able to be employed in generic and light-duty custom control applications using one of three modes (Rooftop, Heatpump, and Fancoil). The VAV controller is a variable air volume controller that is designed to function in numerous scenarios that require variable air volume (VAV), constant air volume (CAV), and CO2 measurement, while providing flexible mounting solutions to increase ease of installation. Since being open simply isn't enough, AAM also offers a group of unitary static pressure (V3Tb) and airflow (V3Td) digital controllers. These enable constant volume air handler units (AHU) to supply variable volumes of air.

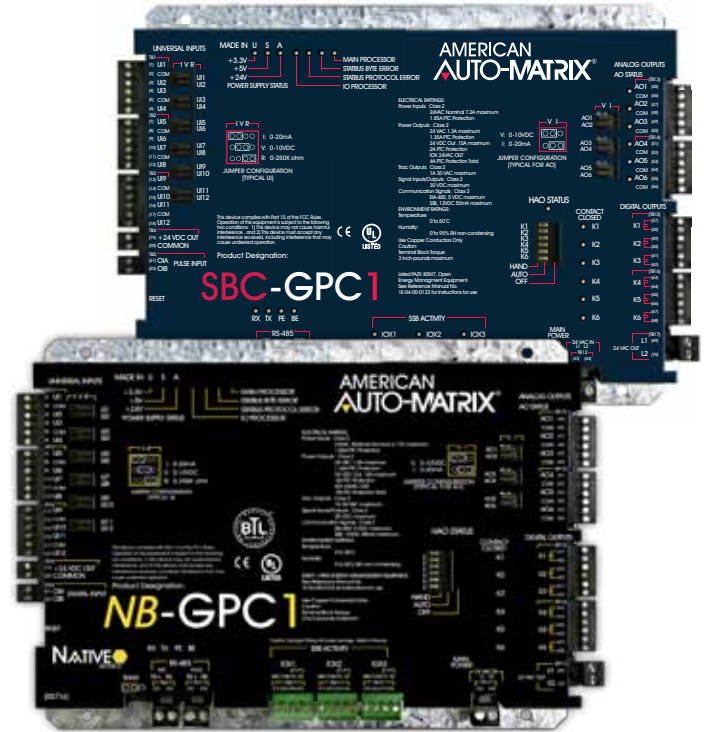

BTL Listed

American Auto-Matrix has over 31 of their Native BACnet® products now carrying the distinguished BTL mark. The procurement of the BTL mark builds more confidence in their capability to provide integratable solutions to the HVAC marketplace.

The BTL mark is a symbol that represents a high quality BACnet® product. Having the BTL mark indicates that their products have passed a series of tests conducted by the BACnet® Testing Laboratory and confirms that their controllers implement the BACnet features stated in the listing. In the industry today it is more common for building owners to seek out products that BTL listed. In addition an increasing number of specifications require products that are BTL certified

American Auto-Matrix has been diligently working since 2008 to have their entire Native BACnet® product line BTL listed. Their mission is almost close to complete with 31 products, which include Auto-Flow Critical Environments, NB-GPC, NB-ASC, NB-VAV, NB-V3T, Matrix Router and Integra Product Families, carrying the BTL mark.



BACnet is a registered trademark of ASHRAE. ASHRAE does not endorse, approve or test products for compliance with ASHRAE standards. Compliance of listed products to requirements of ASHRAE Standard 135 is the responsibility of the BACnet International. BTL is a registered trademark of the BACnet International.

Small Displays



American Auto-Matrix's API Small Display family is a compact, addressable product line of LCD touch screen network display devices for applications on both EIA-485 Public Unitary Protocol™ (PUP): SBC-SD and MS/TP BACnet based networks: NB-SD. It enables users to quickly monitor their system and easily make changes to the way their building is controlled. It is a wall mounted touch-screen operator interface with permission based menu icons, allowing simple navigation to read and write PUP and BACnet® values, view alarms, grouped data, and point descriptions. Also available for AAM's Fume Hood Controllers, the FHC-SD offers multiple levels of configurability and accessibility designed to give users security and safety on a highly visible, live local user interface.



AUTO-FLOW®

CRITICAL ENVIRONMENTS

Auto Flow® Critical Environments Solutions are a complete system designed for fume hood, laboratory, and clean room environments that follows the American Auto-Matrix tradition of offering an unprecedented amount of flexibility, in addition to durability. Through expanding the leading edge GPC technology into the Critical Environments market, with the NB-GPC^{FHC™}, fume hoods can be configured to utilize either Face Velocity or Sash Position methods through a single Native BACnet® controller; the only solution of its kind in the industry.

Through patented technologies as well as other methodologies, combined with Native BACnet® control, installations can connect seamlessly to any American-Auto Matrix HVAC control system, as well as any Native BACnet® compliant system. American Auto-Matrix has the only Native BACnet® solution in the industry. It is the intent of Auto-Flow® to offer solutions that encompass the needs of all parties involved in the Critical Environment process. This is achieved through providing a solution that not only communicates in a widely accepted open protocol, but offers a level of flexibility in which multiple familiar and proven methodologies are available. In addition, through the advanced technologies that they provide, ergonomic functionality will be increased. The goal of their solutions is to create an environment whereby retrofits, new installations, and additions can be achieved without increasing the learning curve or introducing unfamiliar methods or technologies, increasing safety as well as savings.



Access control systems offer an economical and flexible solution for the smart building. Companies throughout the world are using access control systems to monitor the people and assets entering and leaving their facilities, maintain security, manage zone control for high-security areas, and monitor time and attendance.

The philosophy behind the design and development of KeyMaster® was to produce a product that would address the needs of the end-user. Installers are able to configure the system exactly to the requirements of the end-user. Using an easy-to-use graphical interface, the installer can drag and drop icons representing doors, zones, readers, and digital I/O points. For high rise buildings, the KeyMaster® system is ideal, as different user groups can be defined according to companies with general access to shared areas. KeyMaster® integrates nicely into AAM's HVAC control architecture, Biometrics, and CCTV to provide a "Smart Building Solution®".

**Still don't know what your building can say? Still not ready to listen to your building?
All of these building Owners are getting maximum efficiency with minimal effort.**

"Winona Controls worked with the Prairie du Chien Public Schools to do a complete renovation of the HVAC system in the High School. The main project was a complete conversion from steam to hot water and this was no small task as our High School was built in the 1960's. We appreciated how well they worked with our local staff and the architectural firm to accomplish our goals. The project was done on time, even though we had a very aggressive window as the school was not shut down, and it came in within budget parameters." - Drew Johnson, District Administrator at the Prairie du Chien Public Schools

"Winona Controls did a great job of helping us understand our heating and AC equipment needs. We are quite pleased with the computer-based automation program, which allows us to monitor our facility any time, from work or from a remote location. When I call for service during work hours, I always talk to a human, and requests are addressed very timely." - Steve Skifton, St. Mary's Press

"Winona Controls provided solutions to our building automation system needs both during our project and throughout our daily facility operation. Their service technicians provided a support response to us in many areas including controls, programming, mechanical/HVAC, and plumbing. After one year, our building has proven itself, thanks to Winona Controls." - Doug Anderson, Paramark Real Estate Services

Winona Controls

108 Bissen Street
Caledonia, MN. 55921
Toll Free: 1.800.808.7360
Fax: 507.724.5320
winonacontrols@winonacontrols.com
www.winonacontrols.com

American Auto-Matrix

One Technology Lane
Export, PA 15632
Toll Free: 1.877-226-4822
Fax: 724-327-6124
aam@aamatrix.com
www.aamatrix.com



108 Bissen Street wCaledonia, MN 55921 w800.808.7360

building automation wheating wcooling wplumbing wboilers whigh pressure piping